

VDSL2: Next important broadband technology

Per-Erik Eriksson and Björn Odenhammar

ADSL2plus is currently being deployed worldwide as the new mainstream broadband technology for residential and business customers. But at the same time, the industry is gearing up for the next step of the DSL evolution: VDSL2. This second version of the very high-speed digital subscriber line (VDSL) standard from ITU-T promises to deliver 100Mbps symmetrical traffic on short copper loops.

The greater bandwidth of VDSL2 gives telecommunications operators the ability to offer advanced services such as multiple streams of interactive standard and high-definition TV over IP over the existing copper plant. TV services are fast becoming strategically important to telecommunications operators who must now compete head-to-head with cable operators launching voice over IP (VoIP) and high-speed internet services.

The introduction of VDSL2 will have a major impact on the way access networks are engineered. To make the most of VDSL2, operators will have to move the DSL access multiplexers (DSLAM) out of the central office environment and build a distributed network with smaller nodes that sit typically less than 1500 meters away from end users. This puts more stringent requirements on outside plant building practices. In many cases, power and spacing might also be an issue because existing street-side cabinets lack space and often solely contain passive equipment.

Although fiber to every home is the ultimate answer, it is not yet an economically viable solution for overbuilding existing copper networks. This is because fiber takes a long time to deploy and the cost of deployment runs between USD 1,000 and 1,800 per subscriber. However, in Greenfield building scenarios, fiber to the home (FTTH) is frequently seen as the best way forward.

BOX A, TERMS AND ABBREVIATIONS

AAL5	ATM adaptation layer 5	ISDN	Integrated services digital network
ADSL	Asymmetric DSL	ITU-T	International Telecommunication Union – Telecommunication Standardization Sector
ANSI	American National Standards Institute	OC-3	Optical carrier 3
ATM	Asynchronous transfer mode	OFDM	Orthogonal frequency-division multiplexing
BRAS	Broadband remote access server	PHY	Physical link
CPE	Customer premises equipment	PMD	Physical media-dependent
DELT	Double-ended line test	PMS-TC	Physical media-specific – transmission convergence
DHCP	Dynamic host configuration protocol	PON	Passive optical network
DMT	Discrete multitone	POTS	Plain old telephone service
Docsis3	Data-over-cable service interface specifications	PTM	Packet transfer mode
DSL	Digital subscriber line	PVC	Permanent virtual connection
DSLAM	DSL access multiplexer	QAM	Quadrature amplitude modulation
EDA	Ethernet DSL access	QoS	Quality of service
ETSI	European Telecommunications Standards Institute	SAR	Segmentation and reassembly (block processes)
FDD	Frequency-division duplex	SELT	Single-ended line test
FTTB	Fiber to the building	SHDSL	Symmetrical high-bit-rate DSL
FTTCab	Fiber to the cabinet	SNR	Signal-to-noise ratio
FTTEx	Fiber to the exchange	STM	Synchronous transfer mode
FTTH	Fiber to the home	TPS-TC	Transport protocol-specific – transmission convergence
FTTN	Fiber to the node	TV	Television
HDSL	High-bit-rate DSL	US0	First upstream band
HDTV	High-definition TV	UTOPIA	Universal test and operations PHY interface for ATM
HFC	Hybrid fiber copper	VDSL	Very high-speed DSL
IEEE	Institute of Electrical & Electronics Engineers	VLAN	Virtual local area network
IFFT	Inverse fast Fourier transform	VoIP	Voice over IP
IP	Internet protocol		
INP	Impulse noise protection		

DSL history

ADSL

While high-bit-rate DSL (HDSL) was still in prototype phase, Stanford University and AT&T Bell Labs developed asymmetrical DSL (ADSL) technology from concept to prototype (1990-1992). Field technology trials began three years later and ANSI issued the first standard for ADSL in 1995 (T1 413 issue I); the second issue followed in 1998. The first ADSL recommendation from ITU-T (G.992.1), generally denoted ADSL1, was complete in 1999.¹ This recommendation was based to a large extent on the ANSI standards.

ADSL was originally intended for delivering video on demand at a bit rate of 8Mbps downstream and 640kbps upstream. But it was the popularity of the internet that made ADSL a major commercial success. In fact, ADSL is today mainly used as a form of high-speed internet access.

An option in the ADSL1 standard provides for a downstream data rate of up to 12Mbps. Moreover, plain old telephony service (POTS) or integrated services digital network (ISDN) technology can serve as the underlying service (by not using the frequencies occupied by their respective services: 0.3-25kHz for POTS or 1-120kHz for ISDN). A splitter filter can be used to separate the POTS band from the ADSL band. This means ADSL can share the line with either POTS or ISDN service. Figure 1 shows how the frequency band is divided between POTS/ISDN upstream and downstream data.

ADSL2

The second-generation ADSL standards (ADSL2 and ADSL2plus) were issued in 2002 and 2003.^{2,3} The most important new features of ADSL2 (G.992.3) were

- an annex with extended upstream, which made it possible to have an upstream data rate of up to 3Mbps; and
- an annex for extending the reach to more than 5km.

ADSL2plus

The ADSL2plus standard (G.992.5) doubled the spectrum for downstream data (ADSL and ADSL2 have a spectrum of 1.1MHz; ADSL2plus has a spectrum of 2.2MHz), giving even greater data rates on short loops (Figure 1). ADSL2plus also defined a toolbox for sculpturing the downstream transmission to meet different spec-

trum capability requirements, in particular when ADSL2plus is put in a cabinet.

Figures 2-3 show the performance, during different noise conditions, of Ericsson's Ethernet DSL access (EDA) DSLAM for ADSL2 and ADSL2plus.

VDSL

Efforts to standardize VDSL (currently denoted VDSL1) got underway in 1995. ITU, ETSI and ANSI (T1E1.4) each carried out simultaneous projects. In 1997, a group of operators belonging to the Full-service Access Network organization specified the end-to-end requirements for VDSL. The process later stalled, however, due to discord regarding two competing line-code technologies:

- single carrier, which uses quadrature amplitude modulation (QAM); and
- discrete multitone (DMT).

Likewise, major efforts to complete the ADSL2 and ADSL2plus standards moved work on VDSL standardization to a back seat. As a result, proprietary implementations of VDSL-QAM and VDSL-DMT were developed and deployed in limited volumes in a few markets.

In 2003, eleven major DSL suppliers jointly announced their support for DMT line coding, in particular because it facilitates greater interoperability and is more compatible with existing ADSL installations. This decision was also influenced by IEEE's efforts to standardize Ethernet over VDSL as an element of the Ethernet in the first mile (EFM) standard defined in IEEE 802.3ah. A clear objective of the EFM standard was to adopt a single line code in cooperation with established DSL standardization bodies. This started a "VDSL Olympics" of sorts in which the performance of VDSL-QAM was tested against that of VDSL-DMT in independent labs run by British Telecom in the UK and Telcordia Technologies in the USA. VDSL-DMT outperformed VDSL-QAM and was thus adopted by IEEE and ANSI. ITU-T SG 15/4 by contrast included both QAM and DMT in the VDSL1 standard but stipulated that

- all future evolution of VDSL technology would be based on DMT; and
- a new standard, VDSL2, should be defined.⁴

The scope of the VDSL2 standard is quite broad. Its goals are to increase performance over longer loops (longer than VDSL1), as an evolution from ADSL2plus, and very short loops, as an evolution from VDSL1.

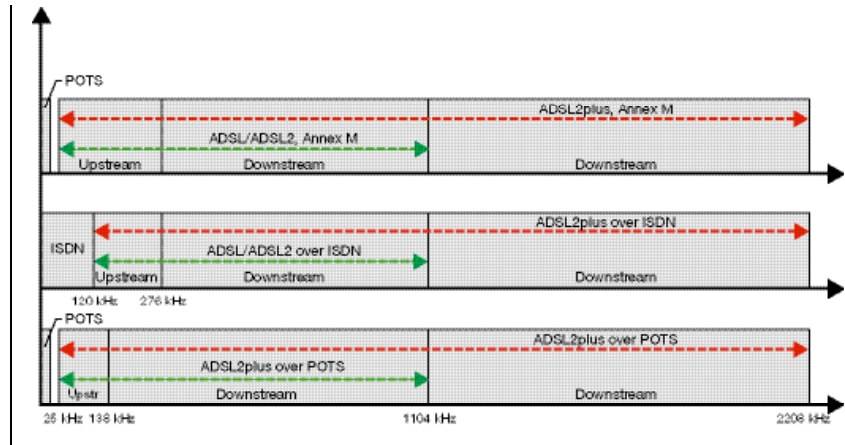
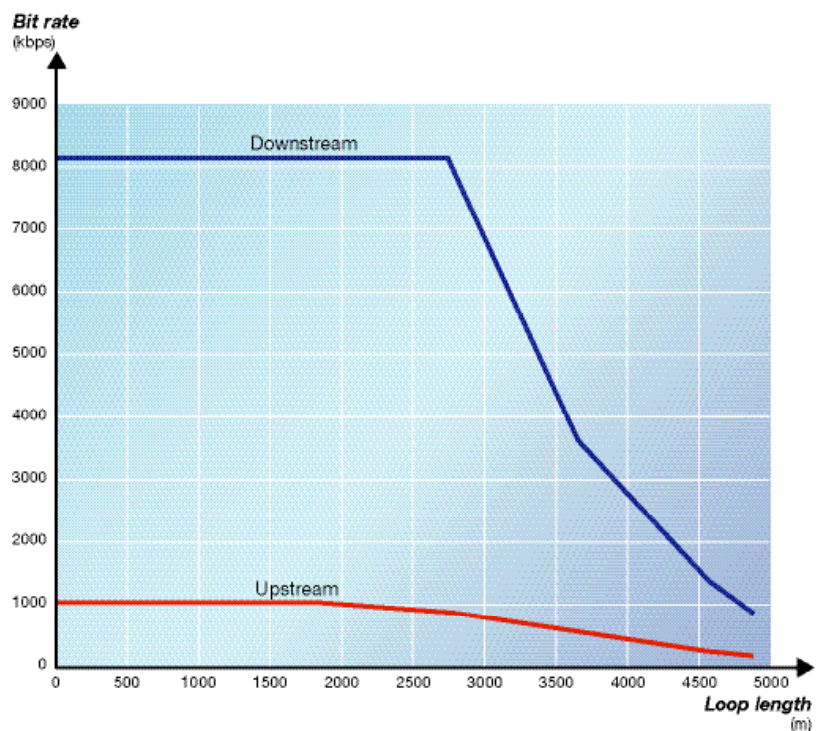

Figure 1
ADSL/ADSL2/ADSL2plus frequency allocation for POTS, ISDN and extended upstream (Annex M) application.

VDSL1 occupies spectrum from 138kHz to 12MHz. The VDSL2 spectrum has been expanded both upward and downward, using spectrum from 25kHz to 30MHz. The

Figure 2
Capacity of ADSL2 over POTS on 0.4mm cable with 24 DSL disturbers.



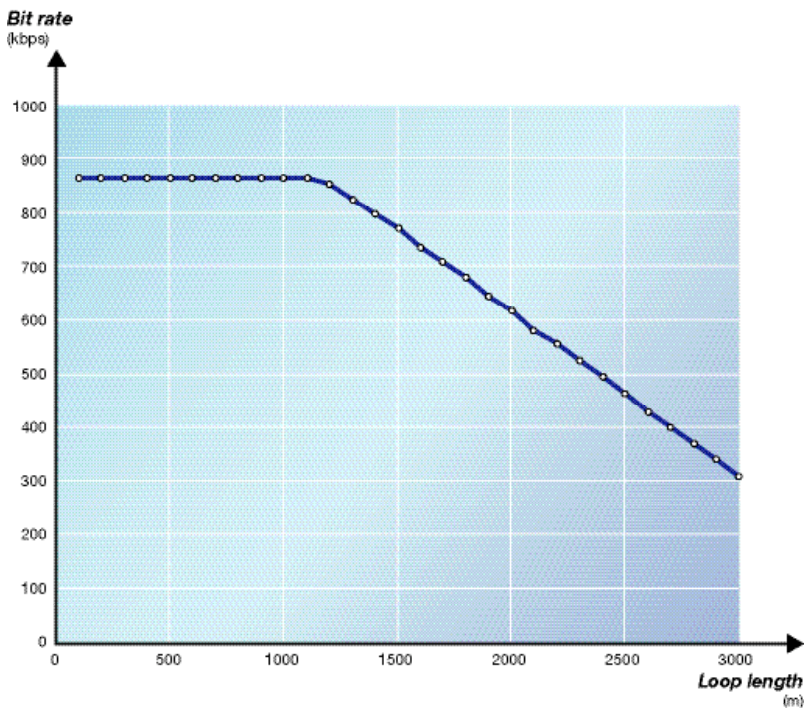
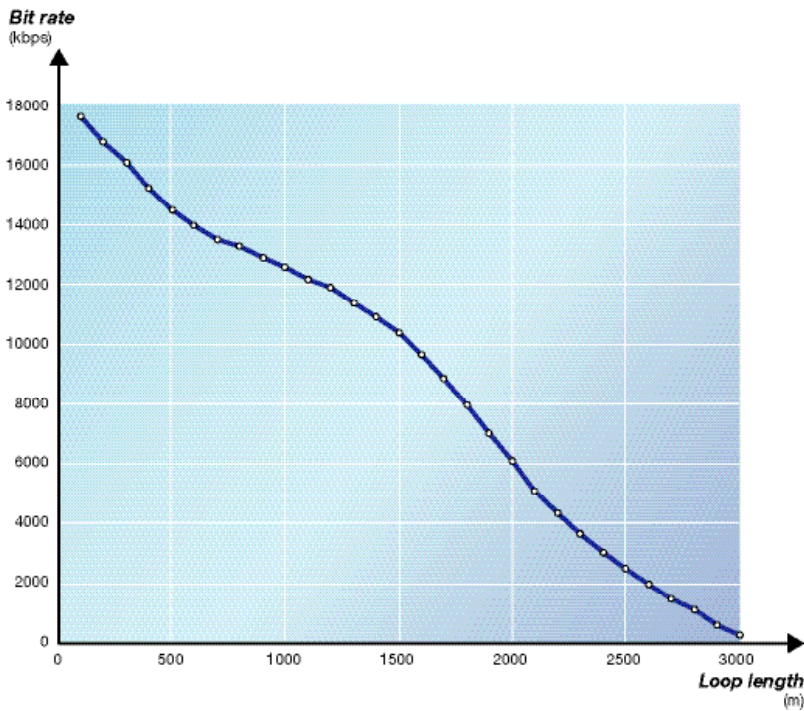

Figure 3
 Top: Downstream capacity of ADSL2plus over POTS with ETSI noise on 0.4mm cable.
 Bottom: Upstream capacity of ADSL2plus with ETSI noise on 0.4mm cable.

key to increasing performance over long loops lies in the use of spectrum from 25kHz to 138kHz. Similarly, the key to increasing performance over short loops lies in the use of spectrum from 12MHz to 30MHz.

The DSL industry successfully transitioned from ADSL to ADSL2plus, doubling the spectrum while maintaining or improving line density and cutting costs. The move to VDSL2 from ADSL2, however, decreases line density due to a significant increase in spectrum. A transition from VDSL1 to VDSL2 can take place without a loss in line density.

Perhaps the most important aspect of the VDSL2 standard is that it uses Ethernet as multiplexing technology (64/65 encapsulation) in the first mile. The elimination of ATM in the first mile means the access architecture can be simplified into an end-to-end Ethernet access architecture that uses virtual local area networks (VLAN) as the service-delivery mechanism across the entire access network.⁶

Ericsson is a driving force behind the architectural transition to high-performance broadband solutions that will propel broadband from mere high-speed internet access technology to a complete suite of IP-based services, such as IP telephony and IPTV. Ericsson introduced the first IP-based DSL access solutions in 2002 and has since worked to refine the architectures required to support the enhanced scope of service.⁵

VDSL2 technology

Using input from the ANSI and ETSI standards, the ITU began drafting its VDSL2 standard (G.993.2) in January 2004. Consensus for the standard was reached at a meeting in Geneva in May 2005. As with ADSL2/plus, the underlying modulation in the VDSL2 standard is discrete multitone (DMT). VDSL2 is based on both the VDSL1-DMT and ADSL2/ADSL2plus recommendations. Therefore, it is spectrally compatible with existing services and enables multimode operability with ADSL2/plus.

DMT modulation

DMT modulation uses the same principle as orthogonal frequency-division multiplexing (OFDM).⁶ That is, it divides the useful frequency spectra into parallel channels, where the center of each channel is represented by a modulated (QAM) subcarrier (Figure 4). One difference from OFDM is

that each carrier in DMT can be loaded with a different number of bits, depending on the signal to noise ratio (SNR). In OFDM, the constellation size of each carrier is the same. Because each subcarrier is orthogonal to the other subcarriers, there is no interference between subcarriers. The number of bits can be varied between 1 and 15. The distance between subcarriers is 4.3125kHz. In VDSL2 a distance of 8.6125kHz may also be used. Inverse fast Fourier transform (IFFT) is used to generate the subcarriers.

Band plans

ADSL can be described as a two-band system where one part of the frequency spectrum is used for upstream transmission and the second part is used for downstream transmission (Figure 1). VDSL, on the other hand, uses multiple bands for upstream and downstream transmissions to enable a greater degree of flexibility with regards to rate configurations and symmetry between upstream and downstream data.

Two band plans were defined (in 2000) to meet operator requirements for symmetry/asymmetry (Figure 5). The first of these, Band Plan 998, better facilitates asymmetric services, whereas Band Plan 997 accommodates symmetric services. VDSL1 supports a bandwidth of up to 12MHz; in VDSL2 this can be extended to 30MHz. To be spectrally compatible with VDSL1, VDSL2 uses the same band plans below 12MHz. VDSL2 can employ up to 4,096 subcarriers. Depending on the band plan in use, a subcarrier is designated for either upstream transmission or downstream transmission. As in ADSL, the lower part of the spectra is allocated for POTS and ISDN service and a splitter filter is used to separate the POTS or ISDN frequencies from the VDSL2 band. An "all digital mode" option also exists, where virtually all the spectra can be used for VDSL2.

Duplexing

Today's deployments of ADSL/2/plus use frequency-division duplex (FDD) technology to separate the upstream band from the downstream band. Given the physical properties, however, it is not possible to create a "brick wall" transmission band. That is, there is always some spectral leakage between the transmission bands. In ADSL, filters or echo cancellers are used to suppress leakage between transmission bands. VDSL, on the other hand, uses a digital duplexing technique based on the "zipper" technology

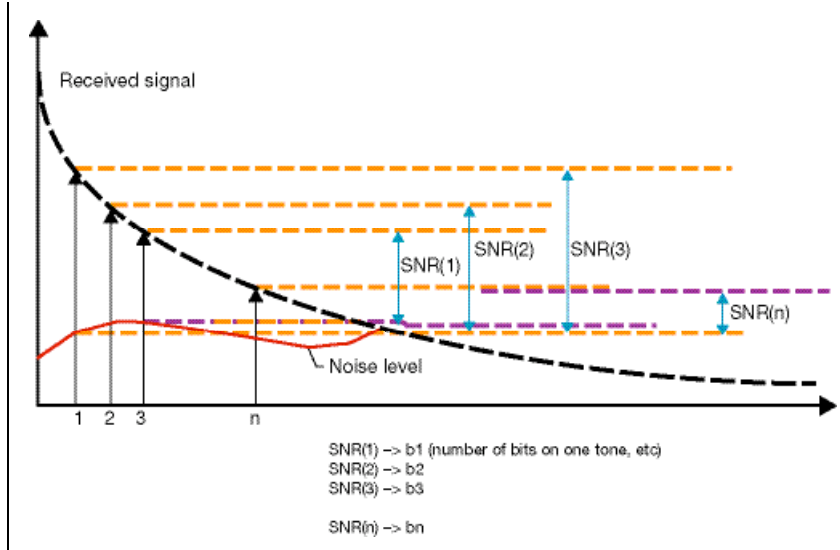
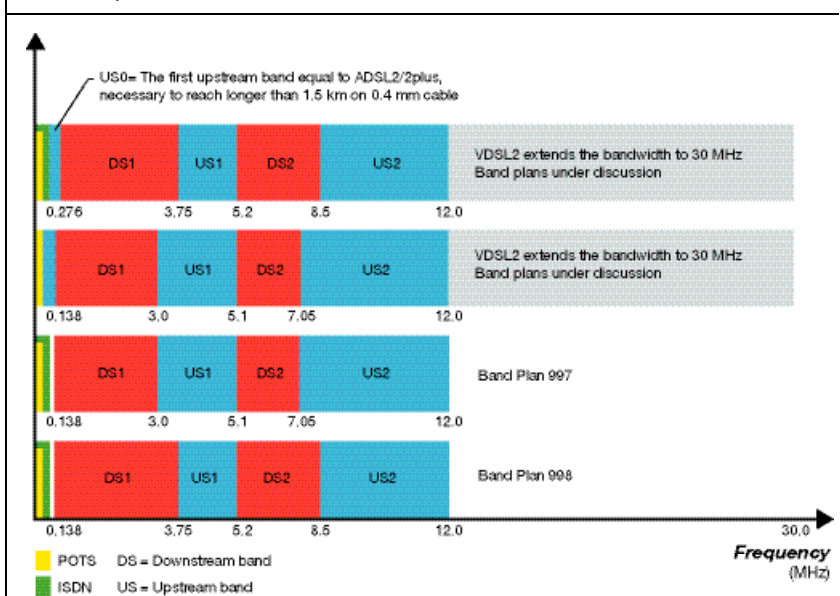

Figure 4
Discrete multitone (DMT): By employing DMT technique one can divide the useful spectra into parallel channels where each channel is represented by a quadrature-amplitude-modulated tone. The signal-to-noise ratio (SNR) value indicates the number of bits with which each tone (1, 2, 3 ... n) can be loaded.

Figure 5
The band plans of VDSL1 and VDSL2.



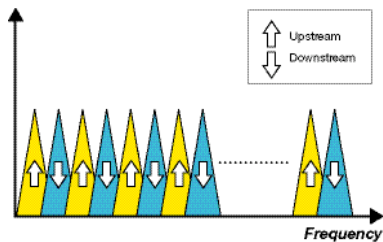

Figure 7
The “zipper” principle of alternating upstream and downstream transmissions to avoid spectral leakage between transmission bands.

invented at Telia Research in Luleå.⁷ With this technique, adjacent subcarriers carry data in opposite directions (Figure 6). However, requirements for spectral compatibility with existing DSL technologies necessitate that several tones must be grouped into transmission bands. One can preserve the orthogonality between the received signal and the transmitted signal echoed back into the receiver by cyclically extending the transmitted DMT symbols using a cyclic prefix and cyclic suffix and by synchronizing the transmitters at each end to begin transmitting at the same time (a technique called timing advance). Cyclic extension, which eliminates intersymbol interference (ISI) caused by the channel, reduces the data rate by 7.8%. Windowing, a technique for suppressing side lobes, further reduces spectral leakage between transmission bands. Windowing is also used in OFDM (Figure 7).

Network evolution when introducing VDSL2

Going forward, the introduction of VDSL2 technology will account for only a small part of the fundamental changes affecting network architecture. Today, the lion’s share of installed access lines is situated in central office environments. Likewise, the average length of existing copper loops is well beyond the “sweet spot” for deriving added value from VDSL2. Many operators have thus already started to consider fiber deeper into the access network – for example, fiber to the node (FTTN) and fiber to the curb (FTTC) – shortening the length of copper loops to less than 1500 meters.

The second major shift is the introduction of Ethernet as packet technology all the way to the end user. ADSL2/plus employs ATM in the first mile but IP/Ethernet-based DSLAMs deploy Ethernet in the second mile. Many legacy broadband solutions also use STM1/OC-3 on the aggregate side.

The shift toward Ethernet and FTTN/FTTC, and the introduction of additional services, will lead to a change in the service selection point in the network (currently the broadband remote access server, BRAS).

FTTN architecture

The push for an FTTN architecture for VDSL2 was initiated by operators in North America, where long copper loops and the early introduction of HDTV call for a steep

increase in broadband capacity. By situating VDSL2 nodes close to subscribers, operators can boost capacity enough to support multiple HDTV streams to a household without having to replace the entire copper infrastructure with fiber. The capacity delivered to each home is on a par with that of a shared fiber architecture, for example, passive optical network (PON) and hybrid fiber copper (HFC) alternatives (Table 1).

The FTTN architecture is also highly distributed to accommodate a smaller number of subscribers per site as DSLAMs are moved closer to end users. A large number of distributed nodes calls for an automated customer-activation process that enables operators to activate a new subscriber without having to physically visit an FTTN location. Many operators eye the FTTN architecture as an attractive tool for effectively competing with cable and fiber-access alternatives.

Challenges of outside plant deployments

Moving the DSLAM out of the central office poses several new technical challenges. The temperature and environmental requirements, for example, are much more stringent. Present-day installations primarily operate in a central office environment with a typical temperature range of -5°C to +45°C. Outdoor plant deployments, on the other hand, must be able to operate in non-climate-controlled environments where temperatures can range from -40°C to +65°C.⁸

Power is another area that will be affected. Most operators currently use -48V power solutions. In most outdoor deployments, however, local power will not be an option. Instead, one must consider remote power (over the existing copper). In metropolitan areas, DSLAMs can be deployed in basements of multidwelling units with access to local power.

Because there are fewer subscribers per site, many vendors will have to revise the architecture behind DSLAM control mechanisms. At present, numerous DSLAMs are optimized for large sites where a common control blade supports an entire cabinet (more than 1,000 subscribers). But with a maximum of, say, 200 subscribers per site, this architecture is not cost-effective.

Ethernet in the first mile

With VDSL2, Ethernet is the basic packet technology all the way out to end users. This change affects the way in which networks are built. A direct benefit of the change is

reduced overhead. The elimination of permanent virtual connections (PVC), which are an inherent part of ATM solutions, opens the door to new architectures. Ethernet-based features, such as VLAN-per-service in combination with authentication using DHCP Option 82, can greatly reduce the costs of operating a network. The simplified network architecture makes it possible to introduce packet transfer mode (PTM) technology. This, and increased requirements to deliver new services with the right QoS, will put new requirements on products and the network architecture. Ericsson has previously outlined many of the architectural principles of IP/Ethernet-based access.⁵

Ericsson's product offering

Ericsson has three years' solid experience of building broadband architectures that can handle advanced, high-quality services with superior performance. Its EDA product line, which was one of the first true IP DSLAMs to be released to the broadband market, is currently in operation in a large number of commercial deployments around the world.

From the outset, Ericsson designed the EDA to be a highly scalable and modular DSL solution based extensively on Ethernet technology. This is precisely what is needed for a network in which VDSL2 is the main technology. In other words, for Ericsson, the first step toward VDSL2 is not very dramatic: Ericsson designed its EDA to be a distributed system with software support for launching new services.

In 2005, to show operators how the technology behaves and what services it supports, Ericsson deployed EDA with VDSL2 in live networks. Some features of EDA worth highlighting in the context of VDSL2 are scalability, advanced single-ended line test (SELT) and double-ended line test (DELT) capabilities, QoS, and greater capacity. Vital objectives of the early deployments were

- to verify VDSL2 performance advantages in real network conditions; and
- to enable an early start of VDSL2 interoperability activities.

Scalability

The EDA VDSL2 nodes can be configured to different sizes in steps of 12 lines. Operators can thus cost-effectively build out numerous small nodes. This proven concept has been in use since 2002 for deploying a large number of 12-, 24-, and 36-line systems (ADSL2plus).

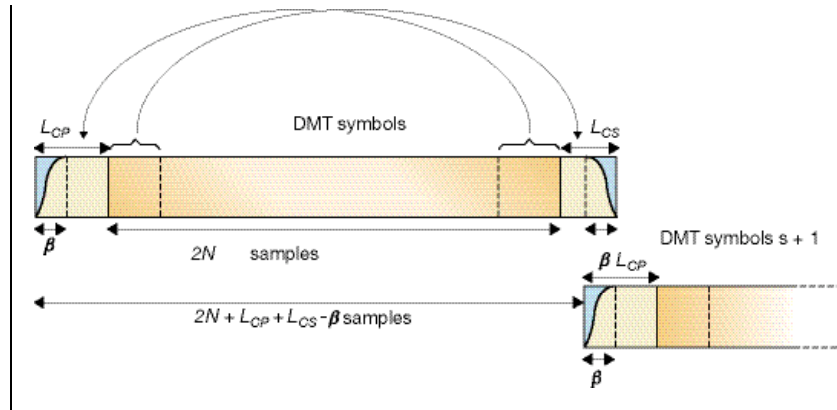

Figure 7

Cyclic extension. A cyclic prefix and cyclic suffix are appended to the DMT symbol. After inverse fast Fourier transform (IFFT), a cyclic prefix and cyclic suffix are appended to the DMT symbol. Samples are copied from the end of the DMT symbol and added to the beginning of the symbol, which represents the cyclic prefix, here denoted L_{CP} . The cyclic suffix is created by copying samples from the beginning of the symbol and adding them to the end of the symbol, here denoted L_{CS} . β illustrates the portion of the symbol that is windowed and added to β samples from the end of the previous symbol, which overlaps with the current symbol.

Advanced SELT and DELT capabilities

Metallic line-test solutions tailored for central office use are expensive. What is needed instead is a software-based line-test solution that makes key line measurements; in particular because outdoor cabinets seldom have space for test heads nor can the cost of providing this space be justified.

QoS

The driving force behind VDSL2 is TV service bundled with voice and data. This will bring an end to the current paradigm of building best-effort DSLAM solutions. To effectively deliver high-quality services, QoS provisions must be built into levels 1 through 3 (L1-3). TV services can easily be delivered using the VLAN-per-service model coupled with features such as Ethernet overload protection and support for dual latency on the physical layer (PHY).

TABLE 1. BANDWIDTH NEEDED TO PROVIDE IPTV SERVICES.

SERVICE	BANDWIDTH REQUIREMENT
1-2 HDTV channels	12Mbps each
2-4 regular TV channels	3Mbps each
High-speed internet	8Mbps
VoIP	100kbps

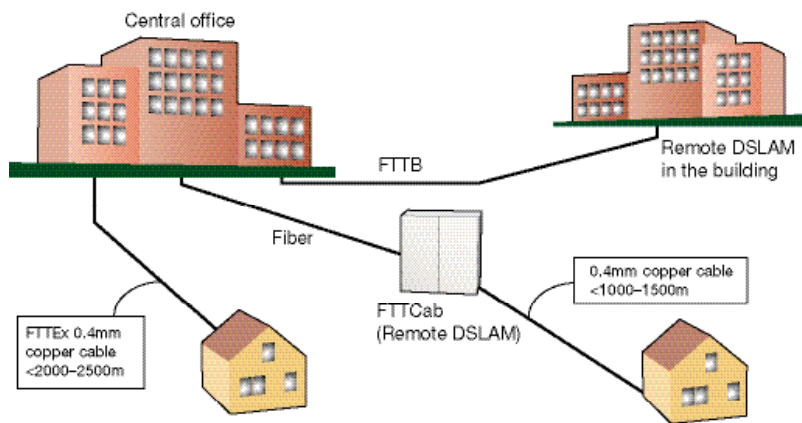

Figure 8
VDSL2 deployment scenarios: fiber to the cabinet (FTTCab), fiber to the exchange (FTTEx), and fiber to the building (FTTB).

Greater capacity

EDA uses distributed processing power all the way out to the line card. When combined with high-capacity Gigabit Ethernet uplinks, this feature provides considerable capacity (packets-per-second throughput). The current rule of thumb for internet services is an average capacity of 25-50kbps per user in the aggregation network. Looking ahead, however, it is estimated that capacity must be increased at least 25- to 50-fold. What is more, apart from the challenge of merely increasing capacity, one must add capacity for QoS-enabled traffic. Ethernet is thus the only truly cost-effective option for increasing capacity. Notwithstanding, even more advanced Ethernet designs are required to support the high capacity of QoS-enabled traffic.

Competing technologies

Some might argue that fiber to the home (FTTH) technology competes with VDSL2. In most cases, however, the two architectures are complementary. The level of FTTx deployment is dependent on the specific business case and is driven by telecommunications operators (as is the case with VDSL2). For operators wanting to migrate to FTTH, the current location of FTTx nodes is a suitable point for splitters or active fiber access nodes. Today's main threat to telecommunications operators comes from the cable industry where new data-over-cable service interface specifications

(Docsis3) technology promises to deliver high-speed solutions that are comparable with VDSL2.

VDSL2 capabilities

Extended reach

Whereas the physical reach of VDSL1 is limited to around 1500m on 0.4mm cable, the reach of VDSL2 can be extended to around 2400m. As a first upstream band (denoted US0) VDSL2 can use the same upstream frequencies as ADSL/2/plus. This extends the reach of VDSL2 compared with VDSL1. The use of US0 requires training sequences similar to those of ADSL to train equalizers and echo cancellers. For distances in excess of 2000-2400m, ADSL2 remains the most appropriate choice of DSL access.

Profiles of different deployment modes

The VDSL2 standard is defined using sets of profiles, where each profile targets a specific deployment. Figure 8 depicts the different deployment scenarios anticipated for VDSL2. These include

- fiber to the exchange (FTTEx): VDSL2 is located at the central office;
- fiber to the cabinet (FTTCab): fiber-fed cabinets are located near customer premises; and
- fiber to the building (FTTB): VDSL2 is placed, for instance, in the basement of a building.

Profiles 8a-8b and 12a-12b apply to FTTEx; 17a applies to FTTCab; and 30a, to FTTB (Figure 9). Each profile contains support for underlying baseband services, such as POTS or ISDN.

Figure 10 shows the measured performance of the EDA VDSL2 with profiles 8a, 12a and 17a during typical noise conditions.

Packet transfer mode

In all likelihood, when introducing VDSL2 the industry will drop ATM in the first mile, replacing it with Ethernet (64/65 encapsulation). At present, the most common solution for transporting Ethernet frames over DSL is bridged IP DSLAM, where Ethernet frames are assembled into ATM adaptation layer 5 (AAL5) and encapsulated into ATM cells before they are sent to the DSL physical link (Figure 11). The Segmentation and Reassembly (SAR) block processes the Ethernet frames. The ATM cells are transported over a UTOPIA (universal test and operations PHY interface for ATM) L2 electrical interface to an application-specific in-

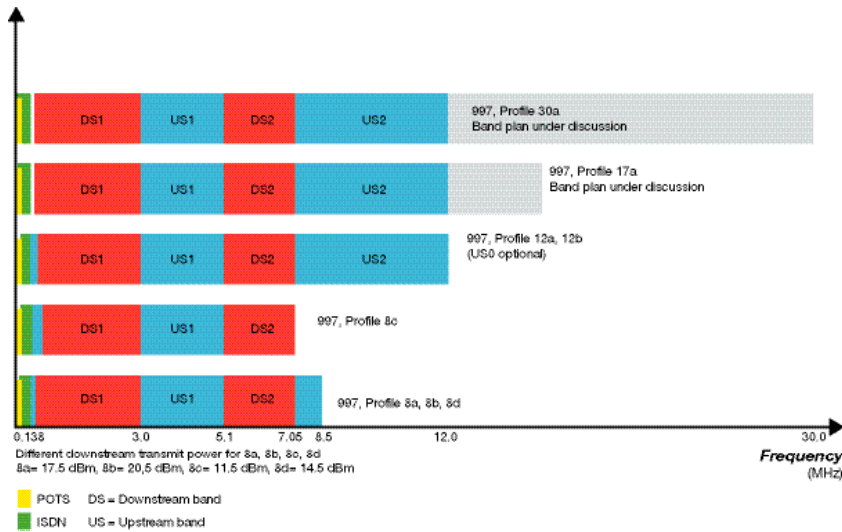

Figure 9
 VDSL2 profiles of Band Plan 997
 (the VDSL2 profiles of Band Plan 998 are similar).

terface called the ATM TPS-TC (transport protocol-specific – transmission convergence). TSP-TC is also sometimes denoted ATM-TC, for example, in the context of the xTU-C (xDSL transceiver unit – central office).

A drawback of encapsulating Ethernet frames into ATM cells (Ethernet-to-AAL5-to-ATM cells) is that 64-byte Ethernet frames must occupy two ATM cells. This is because the payload size of the 53-byte ATM cell is only 48 bytes. Therefore, one ATM cell carries 48 bytes and the other cell carries only 16 bytes. Given the maximum size of an Ethernet frame, 1518 bytes, the ATM overhead is 160 bytes or nearly 10% of the transmission capacity.

IEEE 802.3ah has defined a specific Ethernet TPS-TC using the 64/65-octet encapsulation for Ethernet applications without underlying ATM. For VDSL1, ITU-T specified a different generic packet transfer mode (PTM). In the ITU-T specification, TPS-TC is denoted PTM-TC.

The VDSL2 standard fully supports PTM based on 64/65-octet encapsulation. The IEEE 802.3ah task force defined PTM to encapsulate Ethernet frames before they are modulated in the DSL transceiver. The ITU-T SG15/Q4 has defined PTM for VDSL2 as well as for ADSL2/plus and symmetrical high-bit-rate DSL (SHDSL). Furthermore, it has enhanced the 64/65 encapsulation technique using a preemption method, and added support for non-

Figure 10
 VDSL2 bit rates of different profiles. Real measurement in the presence of crosstalk from 20 VDSL2 systems.

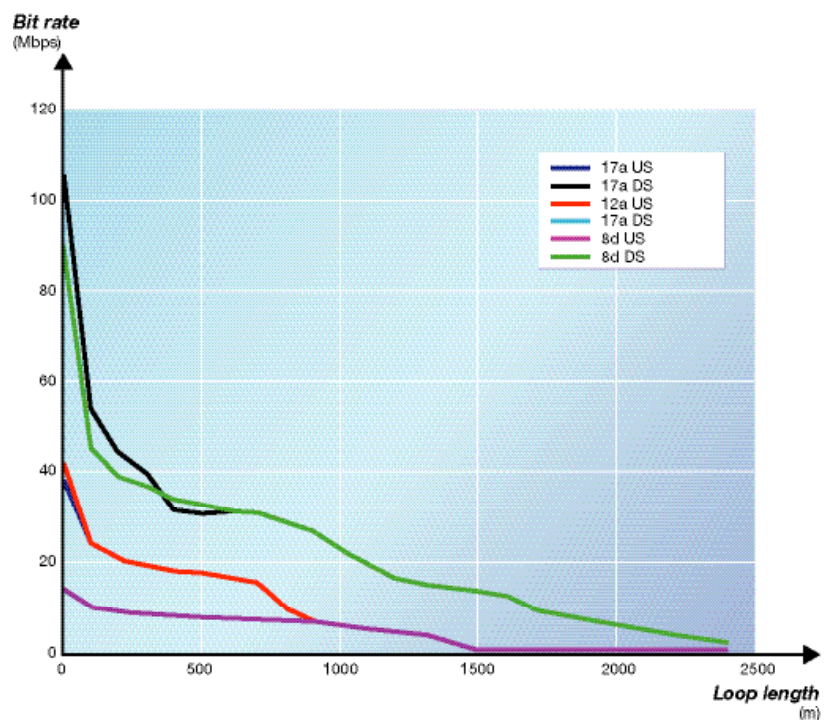
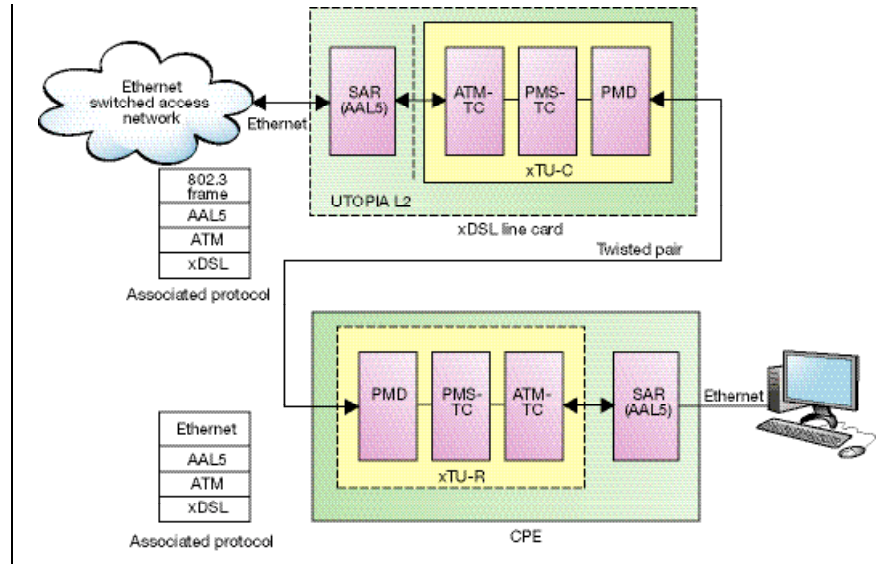

Figure 11
 Logical blocks for xDSL connected to an Ethernet network when ATM is used as layer-2 protocol (bridged IP-DSLAM) in the physical layer (xDSL). Also shown are the associated protocol stacks in the central office and customer premises equipment (CPE).



Ethernet packets that are shorter than 64 bytes in length. PTM thus makes it possible to eliminate ATM as the layer-2 carrier over the physical layer (Figure 12).

Preemption mechanism

The standard 64/65-octet encapsulation technique has been amended with a preemption mechanism that allows high-priority frames to interrupt the transmission of low-priority frames until the high-priority frames have been sent. Transmission of the low-priority frames is then resumed. To

understand how this works, let us assume that a 1518-byte packet with internet traffic is being processed when a high-priority voice packet arrives. The preemption mechanism interrupts transmission of the 1518-byte frame, stores its current state, transmits the voice packet, and then resumes transmitting the packet with internet traffic.

Dual latency

Figure 13 shows a reference model of the VDSL2 transceiver. The TPS-TC serves as an adaptation layer between the transport

Figure 12
 The logical blocks of xDSL connected to an Ethernet Network when ATM as layer-2 protocol is replaced with PTM. This change eliminates the segmentation-and-reassembly (SAR) function, simplifying the protocol stack.

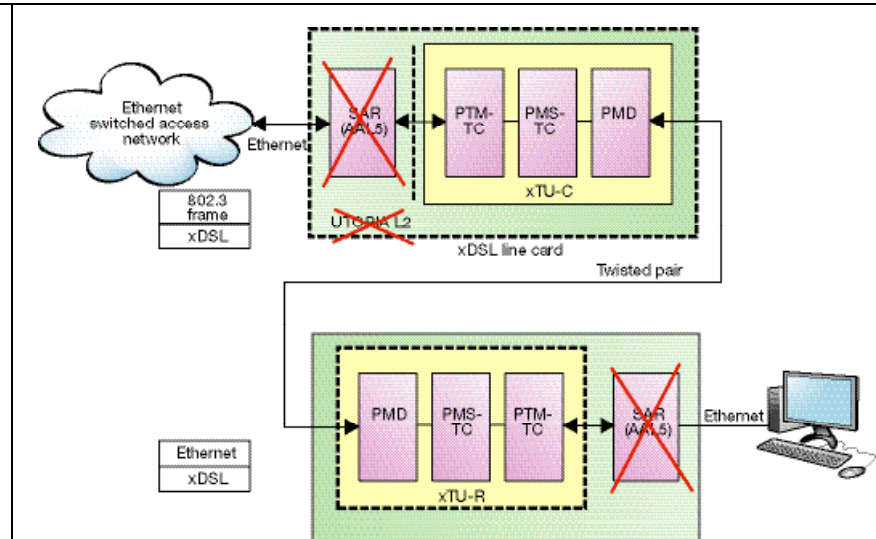

protocols and the digital subscriber line. Ethernet frames or ATM cells are input into TPS-TC. Among other things, the TPS-TC layer provides the transport mechanism, encapsulates frames or cells, and decouples input and output rates.

The next station is the PMS-TC (physical media-specific – transmission convergence) layer, which provides latency path functions. These functions determine the error-protection capability (together with Trellis coding) and latency. Framing also takes place in the PMS-TC.

Ordinarily, only one latency path is implemented in ADSL2/plus. This is not a limitation of the standard, however. Examination of the latency path (Figure 14) shows that an interleaver used together with Reed-Solomon code creates a powerful error-protection mechanism. However, the interleaver introduces delay proportional to its depth; that is, if there is only one latency path and interleaving is used, then every service experiences the same delay.

Services such as video, which must be immune to short bursts of errors, must have great interleaver depth. As a consequence, they also experience significant delay. Video service is not sensitive to delay, however, provided there is little jitter. Voice and gaming services, on the other hand, do not require extensive error protection but they are very sensitive to delay.

A dual-latency solution provides a second latency path in the PMS-TC. Data that must be protected uses the interleaved path while data that is sensitive to delay can use the path without interleaving or with only a minimum of interleaving. Eventually, the data streams from each of the latency paths are multiplexed into a single bit stream that is conveyed to the physical media-dependent (PMD) layer for modulation. The number of bits taken from each latency path and put into one DMT frame is determined during initialization. The output from the PMD layer is the analog signal delivered to the analog front end. Operators have indicated that they want the dual-latency option in VDSL2 in order to provide the QoS required of triple-play services.

Power control for improved spectral compatibility

VDSL2 will mostly be used on short loops, pushing DSLAMs further out into the net-

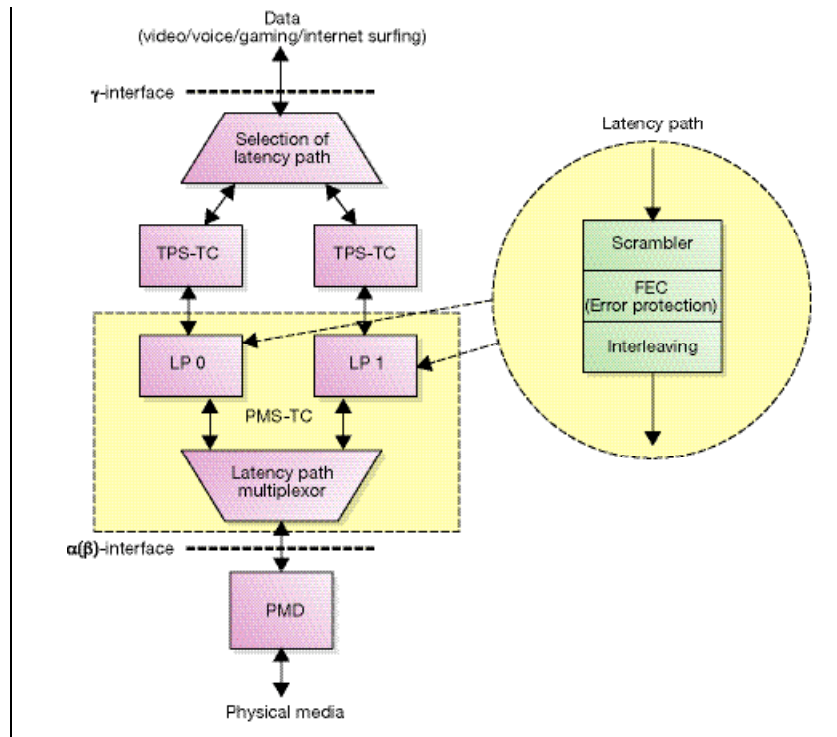

Figure 13
Reference model of the transceiver. The dotted lines indicate an optional latency path.

work closer to user premises. It is anticipated that FTTCab deployments will increase in all operator networks. However, services such as ADSL2/2plus, which are operated from a central office environment and which share the binder used for VDSL2 in the cabinet might experience severe degradation of downstream data performance due to crosstalk from VDSL2 systems. Power control can be used to shape the downstream VDSL2 signal. This minimizes the impact of crosstalk from VDSL2 systems on central office-based ADSL2/plus systems without penalizing the downstream VDSL2 signal.

Upstream power backoff

When different sets of VDSL2 customer premises equipment (CPE) are located at unequal distances from the central office or the cabinet, the transmission of users closest to the central office or cabinet disturbs the upstream transmission of other users (near-far phenomenon, Figure 14).⁹ A simple remedy to this problem is to back off the upstream power of users closest to the central office or cabinet. An algorithm is thus used

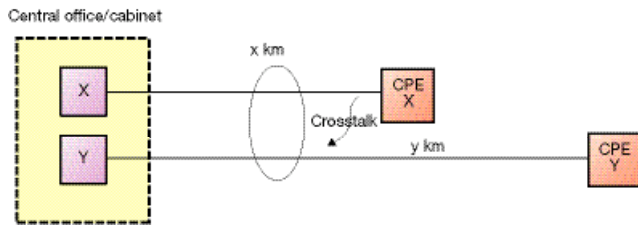

Figure 14
Near-far phenomenon. The signal from CPE X is stronger than the signal from CPE Y, which is attenuated by loop $y-x$. As a result, crosstalk from CPE X leaks into the upstream signal from CPE Y. The solution is to back off the power of CPE X.

to give every user within a given radius of the central office or cabinet the same upstream capacity.

Loop diagnostics mode

To facilitate fault diagnosis, VDSL2 has a loop diagnostic mode and DELT similar to that defined for ADSL2/plus. VDSL2 transceivers can measure line noise, loop attenuation, and signal-to-noise ratio (SNR) at each end of the line. The measurements can be collected even when line conditions are too poor to enable a connection. In this case, as part of the loop diagnostic mode, the modem goes through each step of initialization but with improved robustness in order to exchange the test parameters.

Impulse noise protection

Electrical appliances and installations at customer premises often generate short bursts of noise of relatively high amplitude. These bursts, called impulse noise, are electromagnetically coupled into the digital subscriber line, degrading performance and in some cases disrupting service. The ADSL2/plus standard introduced a parameter (impulse noise protection, INP) that allows operators to select the maximum impulse length that the system can correct. VDSL2 uses this same parameter. In effect, an INP value of between 2 and 16 can correct errors from noise impulses ranging from $250\mu\text{s}$ to 3.75ms in length.

Interoperability

Interoperability between vendors is a prerequisite of mass-market technology. Interoperability testing has thus had a vital role in paving the way for today's commercial success of DSL: nearly 19 million digital subscriber lines were rolled out during the third quarter (Q3) of 2005.¹⁰

The DSL Forum is the main driving force behind interoperability. The actual interoperability tests are performed via "plug fests" which are run by several independent test labs around the world. An advocate of open interfaces, Ericsson has been an active participant at these events. For ADSL2plus, the TR-067 (formerly TR-048) specifies in detail how interoperability is to be tested.

Extensive interoperability testing has opened the door to separate DSLAM and CPE markets in many countries.

VDSL2 interoperability

The initial VDSL standard was never fully embraced by the market due to disagreements during standardization regarding modulation scheme (DTM or QAM) and packet technology (ATM or Ethernet).

Broad industry consensus and interoperability testing of VDSL2 is at the top of vendor agendas in 2006. A first meeting for chipset vendors took place at the end of January at the University of New Hampshire InterOperability Laboratory. Experience from working with ADSL tells us it will take at least 12 months to reach full interoperability in the market: for ADSL2plus the process from agreement on the standard to interoperability in the market took nearly 18 months.

The first step in the process is to gain layer-1 interoperability between chipset vendors. With that hurdle cleared, system vendors can perform additional tests between CPE and DSLAMs.

The DSL Forum is defining the framework for the VDSL2 tests in several important documents that will guide the industry forward. The two main documents currently under development are:

- WT-114: VDSL2 Performance Test Plan that sets performance targets (taking into consideration the specific profiles of different regions); and
- WT-115: VDSL2 Functionality Test Plan that forms the basis for operators who are homologating VDSL2 standards compliance.

Backward compatibility

The decision to retain ATM as multiplexing scheme helped keep migration from ADSL1 to ADSL2plus relatively simple because the new IP-DSLAMs were backward compatible with the installed base of ADSL1 CPE. Therefore, migration on the line side did not affect the CPE side.

The migration from ADSL2plus to VDSL2, however, will require considerably more planning at an early stage. ADSL/2/2plus always employs ATM on the copper loop, but VDSL2 will mostly be deployed using Ethernet technology. Even so, VDSL2 chipsets generally allow for the configuration of ATM or IP on a per-port basis, thereby guaranteeing backward compatibility with the installed base of ADSL and ADSL2plus. This fallback feature comes into play automatically during the initialization phase between CPE and DSLAM.

Conclusion

ADSL2plus is being deployed worldwide as the new mainstream broadband technology for residential and business customers. But at the same time, the industry is gearing up for the next step of the DSL evolution: VDSL2. The greater bandwidth of VDSL2 gives telecommunications operators the ability to offer advanced services (such as multiple streams of interactive standard and high-definition TV over IP) over the existing copper plant.

Ericsson is a driving force behind the architectural transition to high-performance broadband solutions that will propel broadband from mere high-speed internet access technology to a complete suite of IP-based services. The company introduced its first

IP-based DSL access solutions in 2002 and has since worked to refine the architectures required to support the enhanced scope of service.

The scope of the VDSL2 standard is quite broad. Its goals are to increase performance over longer loops (longer than VDSL1), as an evolution from ADSL2plus, and very short loops, as an evolution from VDSL1. Perhaps the most important aspect of the VDSL2 standard is that it uses Ethernet as multiplexing technology (64/65 encapsulation) in the first mile. The elimination of ATM in the first mile means that the access architecture can be simplified into an end-to-end Ethernet access architecture that uses VLANs as the service-delivery mechanism across the entire access network. A direct benefit of this change is reduced overhead.

Because VDSL2 is based on both the VDSL1-DMT and ADSL2/ADSL2plus recommendations, it is spectrally compatible with existing services and enables multi-mode operability with ADSL/2/plus.

Ericsson has three years' solid experience of building broadband architectures that can handle advanced, high-quality services with superior performance. Its EDA product line is currently in operation in a large number of commercial deployments around the world. In 2005, to show operators how the technology behaves and what services it supports, Ericsson deployed EDA with VDSL2 in live networks. Some features of EDA worth highlighting in the context of VDSL2 are scalability, advanced SELT and DELT capabilities, QoS, and greater capacity. Vital objectives of the early deployments were to verify VDSL2 performance advantages in real network conditions, and to enable an early start of VDSL2 interoperability activities.

Interoperability between vendors is a prerequisite of mass-market technology. Interoperability testing has thus had a vital role in paving the way for today's commercial success of DSL. Broad industry consensus and interoperability testing of VDSL2 is at the top of vendor agendas in 2006.

REFERENCES

1. ITU-T Recommendation G.992.1 (1999), Asymmetric digital subscriber line (ADSL) transceivers
2. ITU-T Recommendation G.992.3 (2005), Asymmetric digital subscriber line transceivers 2 (ADSL2)
3. ITU-T Recommendation G.992.5 (2005), Asymmetric digital subscriber line (ADSL) transceivers – extended bandwidth ADSL2 (ADSL2plus)
4. ITU T Recommendation G.993.1 (2004), Very high speed digital subscriber line
5. Begley, M.: The Public Ethernet – The next-generation broadband access network. Ericsson Review, Vol. 81(2004):1, pp. 52-59
6. J.A.C. Bingham. "Multicarrier Modulation for Data Transmission: An idea Whose Time has come". IEEE Communications Magazine, 28(4):5-14 April 1990
7. F. Sjöberg, M. Isaksson, P. Ödling, S. K. Wilson, and P. O. Börjesson "Zipper: A Duplex Method for VDSL Based on DMT," IEEE Trans. Commun., vol. 47, pp. 1245-1252, Aug. 1999
8. ETSI 300 019-1 class 3.4 environmental requirements
9. K. Jacobsen "Methods of Upstream Power Backoff on Very High-Speed Digital Subscriber Lines", IEEE Communications Magazine March 2001
10. http://www.broadbandtrends.com/Report%20Summary/2005/BBT_3Q05DSLmkt-Share_051250_Summary_TOC.pdf